

# TOP- TOP-GM

## Ponorná drenážní čerpadla

 Čistá voda

 Domácí použití



### PERFORMANCE RANGE

- Flow rate up to **360 l/min** (21.6 m<sup>3</sup>/h)
- Head up to **15.5 m**

### APPLICATION LIMITS

- Immersion depth:
  - up to **3 m** for TOP 1-2-3
  - up to **5 m** for TOP 4-5  
(with a sufficiently long power cable)
- Maximum liquid temperature **+40 °C**  
(Maximum liquid temperature +90 °C for a maximum of 3 minutes intermittent service)
- Passage of suspended solids up to **Ø 10 mm**
- Suction level:
  - **14 mm** above ground level for TOP 1-2-3
  - **30 mm** above ground level for TOP 4-5
- Continuous service **S1**

### CONSTRUCTION AND SAFETY STANDARDS

The pumps are complete with:

- **5 m** long power cable for TOP 1-2-3
- **10 m** long power cable for TOP 4-5
- float switch

EN 60335-1  
IEC 60335-1  
CEI 61-150

EN 60034-1  
IEC 60034-1  
CEI 2-3



### CERTIFICATIONS

Company with management system certified DNV  
ISO 9001: QUALITY  
ISO 14001: ENVIRONMENT AND SAFETY



### INSTALLATION AND USE

The **TOP** series is suitable for use with **clear water** that does not contain abrasive particles.

Because of the design solutions that have been adopted, such as the complete cooling of the motor and the shaft with double seal, these pumps are easy to use and reliable.

They are suitable for use in applications such as draining small flooded areas (rooms, cellars, garages) in the event of an emergency, for the disposal of waste water in the home (from dishwashers, washing machines) and for emptying drainage traps.

### PATENTS - TRADE MARKS - MODELS

- Registered EU Design n. 342159-0011

### OPTIONS AVAILABLE ON REQUEST

- **"TOP-GM"** pumps with vertical float switch (suitable for particularly small wells)
- **"TOP 2-3 LA"** pumps intended for use with aggressive liquids
- Special mechanical seal
- TOP 1-2-3 pumps with **10 m** long power cable
  - ➡ N.B. Standard EN 60335-2-41 states that the power cable must be 10 m long for outdoor applications
- Pumps without float switch
- Other voltages or 60 Hz frequency

## PRACOVNÍ CHARAKTERISTIKY

50 Hz n = 2900 ot./min.

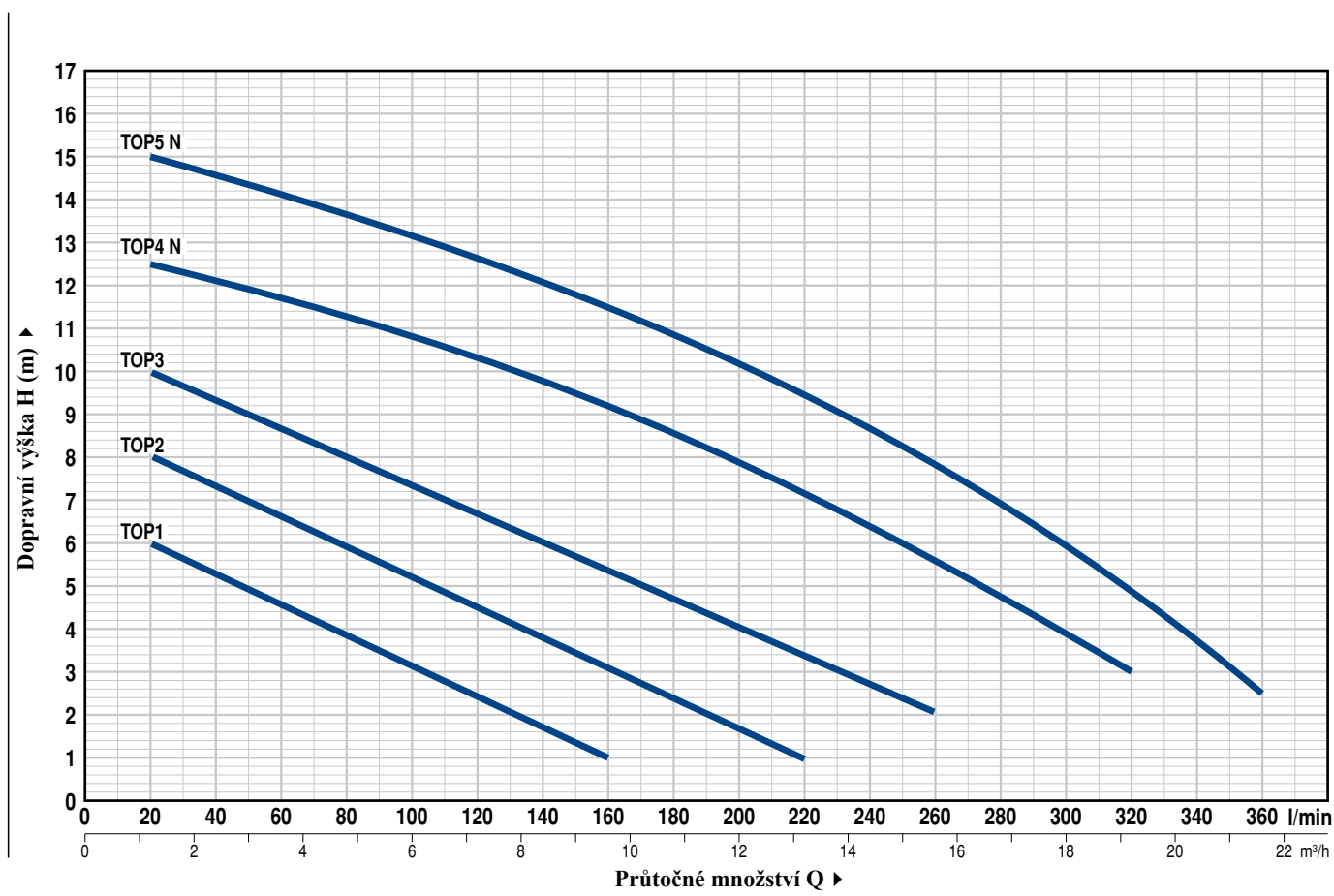

Typy čerpadel Jednofázová	Výkon (P2)		Q	H (m)																							
	kW	HP		0	1.2	2.4	3.6	4.8	6.0	7.2	8.4	9.6	10.8	12	13.2	14.4	15.6	16.8	18.0	19.2	20.4	21.6					
			l/min	0	20	40	60	80	100	120	140	160	180	200	220	240	260	280	300	320	340	360					
<b>TOP 1</b>	0.25	0.33		7	6	5.5	4.5	4	3	2.5	1.5	1															
<b>TOP 2</b>	0.37	0.50		9	8	7.5	6.5	6	5.5	4.5	4	3	2.5	1.8	1												
<b>TOP 3</b>	0.55	0.75		10.5	10	9	8.8	8	7.5	6.5	6	5.5	4.8	4	3.5	2.5	2										
<b>TOP 4 N</b>	0.75	1		13	12.5	12.1	11.6	11.3	10.8	10.3	9.8	9.2	8.5	7.9	7.1	6.4	5.5	4.7	3.9	3							
<b>TOP 5 N</b>	0.92	1.25		15.5	15	14.5	14.1	13.6	13.2	12.6	12	11.5	10.8	10	9.4	8.5	7.8	6.8	6	4.8	3.6	2.5					

Q = Průtokné množství H = Dopravní výška

Tolerance pracovních charakteristik v souladu s normou EN ISO 9906 Třída 3B.

# TOP 1-2-3

## POZ. SOUČÁSTI

## KONSTRUKČNÍ CHARAKTERISTIKY

1	PLÁŠŤ ČERPADLA	Technopolymer
2	KRYT SÁNÍ	Technopolymer
3	VÍKO SÁNÍ	Nerez ocel AISI 304 (AISI 316L u verze LA)
4	ROZVADĚČ	Technopolymer
5	OBĚŽNÉ KOLO	Noryl FE1520PW
6	PLÁŠŤ MOTORU	Nerez ocel AISI 304 (AISI 316L u verze LA)
7	VÍKO MOTORU	Nerez ocel AISI 304
8	HŘÍDEL vč. ROTORU	Nerez ocel EN 10088-3 - 1.4104 (AISI 316L u verze LA)
9	Mechanická ucpávka ze strany hydrauliky a Gufero ze strany motoru v olejové lázni	

Čerpadlo Typ	Ucpávka Typ	Hřídel Rozměr	Materiálové provedení			
			Stacionární díl	Rotující díl	Elastomer	Kov
TOP 1-2-3	STA-12R	Ø 12 mm	Keramika	Uhlík	NBR	AISI 304
TOP 1-2-3 GM	AR-12R LA	Ø 12 mm	Keramika	Uhlík	NBR	AISI 316

10	GUFERO	Ø 12 x Ø 19 x H 5 mm
11	LOŽISKA	6201 ZZ / 6201 ZZ

## 12 KONDENZÁTOR

Typ čerpadla	Kondenzátor	
Jednofázové	(230 V nebo 240 V) (110 V)	
TOP 1	10 µF 450 V	16 µF - 250 V
TOP 2	10 µF 450 V	16 µF - 250 V
TOP 3	14 µF 450 V	16 µF - 250 V

## 13 ELEKTROMOTOR

TOP: jednofázové provedení 230 V - 50 Hz  
s tepelnou pojistkou ve statorovém vinutí

- Izolace: Třída F
- Krytí: IP X8

## 14 RUČKA vč. KABELÁŽE (zalito pryskyřicí)

Ručka vč.:  
- přívodní kabel "H07 RN-F" vč. zástrčky v délce 5 m  
- plovákový spínač  
(magnetický plovákový spínač pouze u verze GM)

## 15 HADICOVÉ ŠROUBENÍ

Ø 25 mm u řepadla TOP 1  
Ø 35 mm u čerpadel TOP 2-3

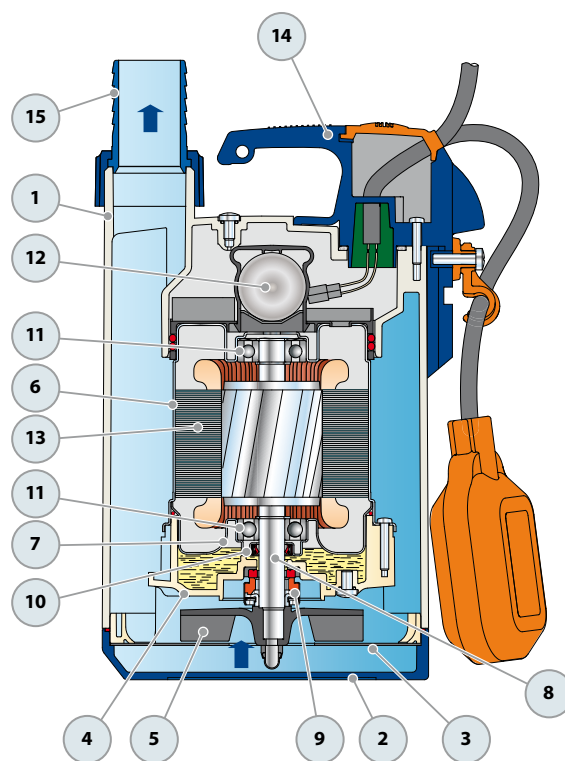

## ROZMĚRY A HMOTNOSTI

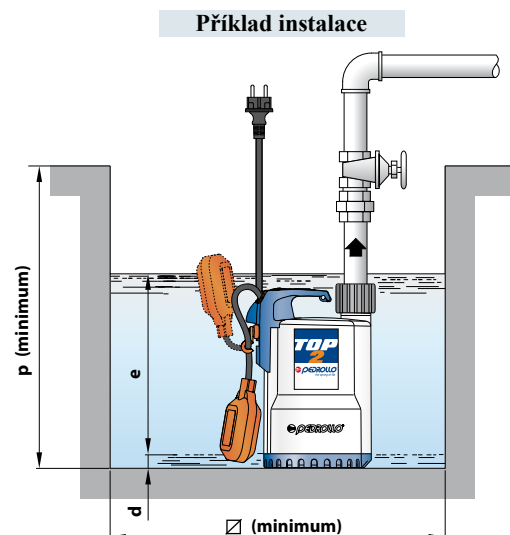
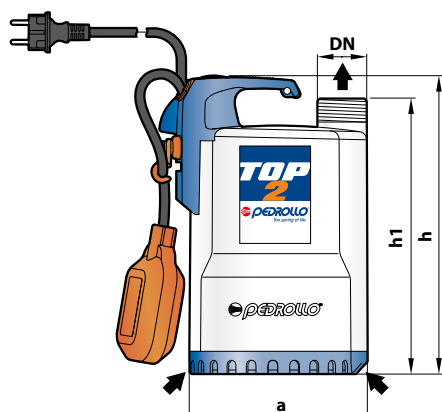

Typy čerpadel Jednofázová	Připojení DN	Rozměry v mm							Kg
		a	h	h1	d	e	p	Ø	
TOP 1	1¼"	152	257	237	14	nastavitelné	350	350	5.2
TOP 2			287	267					5.2
TOP 3			287	267					6.6

### Varianta s magnetickým plovákovým spínačem

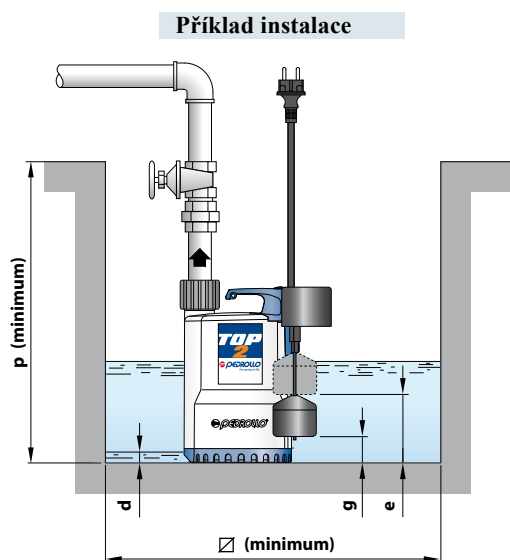
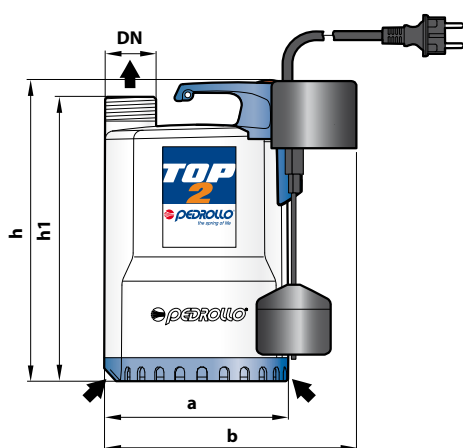

Typy čerpadel Jednofázová	Připojení DN	Rozměry v mm									Kg
		a	b	h	h1	d	e	g	p	Ø	
TOP 1-GM	1¼"	152	200	257	237	14	140	35	350	220	5.3
TOP 2-GM				287	267		170	40			5.3
TOP 3-GM				287	267		170	40			6.7

## PROUDOVÉ HODNOTY

Typy čerpadel Jednofázová	Napětí		
	230 V	240 V	110 V
TOP 1	1.5 A	1.4 A	3.0 A
TOP 2	2.0 A	1.9 A	5.3 A
TOP 3	3.2 A	3.1 A	7.9 A
